

FM Series Foot Mounted Load Cells

P-2012-1
819-0401

Installation Instructions

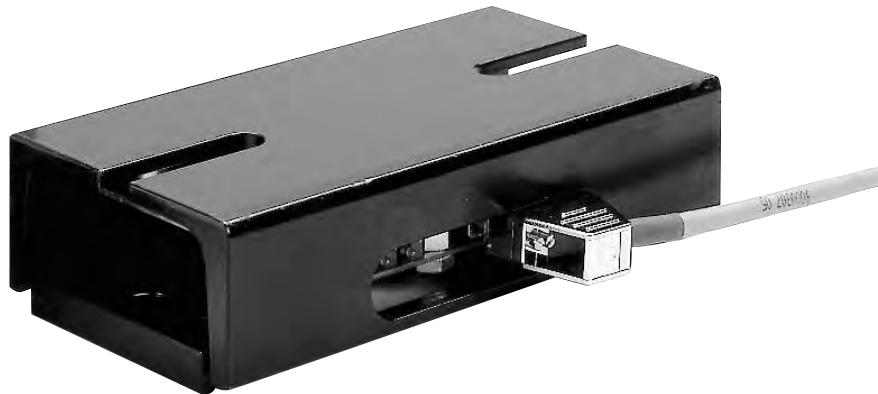

Contents

Specifications	3
Wiring Hookup	4
System Example	4
Dimensions	5
Warranty	Back Page

⚠ WARNING Failure to follow these instructions may result in product damage, equipment damage, and serious or fatal injury to personnel.

The FM style load cell provides easy and convenient mounting to the roll that is being measured (used with pillow blocks). The load cell is a strain gauge style unit that is ideal for heavy tension applications. It can be mounted regardless of orientation, but has to work in compression. Only the perpendicular force (resultant) is measured by the load cell. The perpendicular force can be at a maximum permitted angle of +/- 30 degrees. Correct load cell sizing must be adhered to so potential overload forces do not damage cells.

Specifications:

Load Ratings	N	100	250	500	1000	2500	5000	10000
Size	(Lbs.)	(22)	(56)	(112)	(225)	(562)	(1124)	(2248)
		01	01	01	01	01	01	02

Input Power

±12 to ±15 VDC
 @ 45 MA ±5%

Output Signal

5VDC output at rated load

Temperature Range

0-70 degrees C
 (32 -158 degree F)

Temperature drift

0.1 % of rating per degree C

Non-linearity and Repeatability

< 0.5%

Power Consumption

1 Watt

Cable

16 ft. provided with load cell

Maximum Load Ratings (See Figure 6)

Overload

120% of rated load

Compression Overload

150% of rated load

Horizontal Load

50% of rated load

Model Numbers/Part Numbers

FM01-100	6910-840-100
FM01-250	6910-840-102
FM01-500	6910-840-104
FM01-1000	6910-840-106
FM01-2500	6910-840-108
FM01-5000	6910-840-110
FM01-10K	6910-840-112

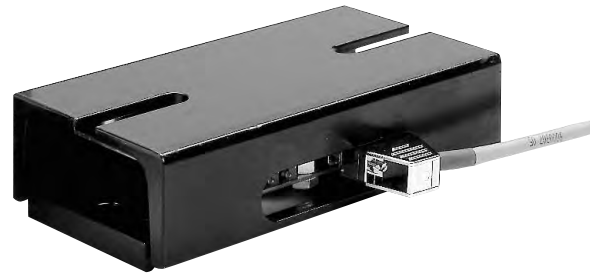

FM Series Part Numbers

FM **01** - **1000** - **AC**
 Model Size Load in N Amplifier built in

Alignment



Figure 1

The sensor has been factory calibrated:

- 0VDC (No load)
- 5VDC (Rated load)

Two potentiometers and LED's are located near the "D" connector (See Figure 1) for visual indication. When used in the nominal range, both LED's are "ON". Although the load cell has been factory calibrated. The unit may be rescaled if necessary. It is recommended that a qualified technician do this procedure.

Attach a digital volt meter between the signal lead (yellow) and 0VDC (ground). With no load on the cell adjust the zero potentiometer for a 0VDC output. The zero setting LED should be "OFF". Any voltage above 0VDC, the zero LED will turn "ON".

Apply the maximum load to the cell. Adjust the gain potentiometer for a 5VDC output reading. The gain LED should be "OFF" at a 5VDC output level. Remove the load and insure the gain LED is "ON".

The zero and gain adjustments may need to be repeated a couple of times to insure proper setting.

Wiring Hookup:

The load cell requires a +15VDC and a -15VDC power supply. The 5V/15V switch inside the MCS2000-CTLC must set to +/-15VDC. Terminate all unused wires from cable.

Wiring example using One Load Cell with the MCS2000-CTLC control

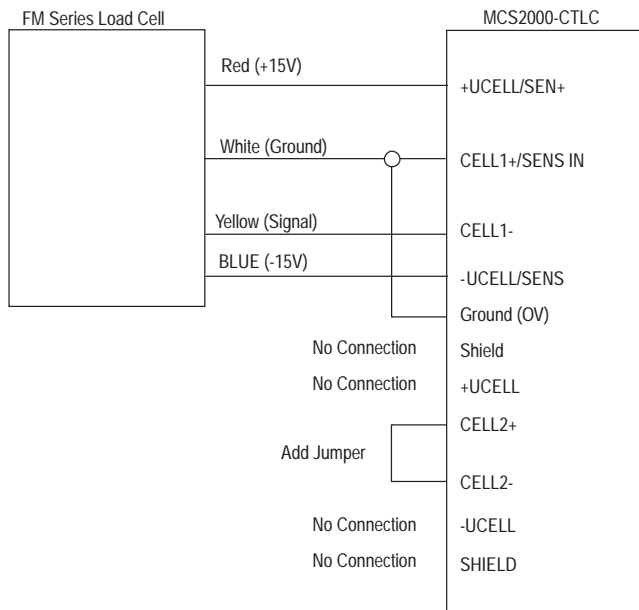

Figure 2

Wiring example using 2 load cells with the MCS2000-CTLC control

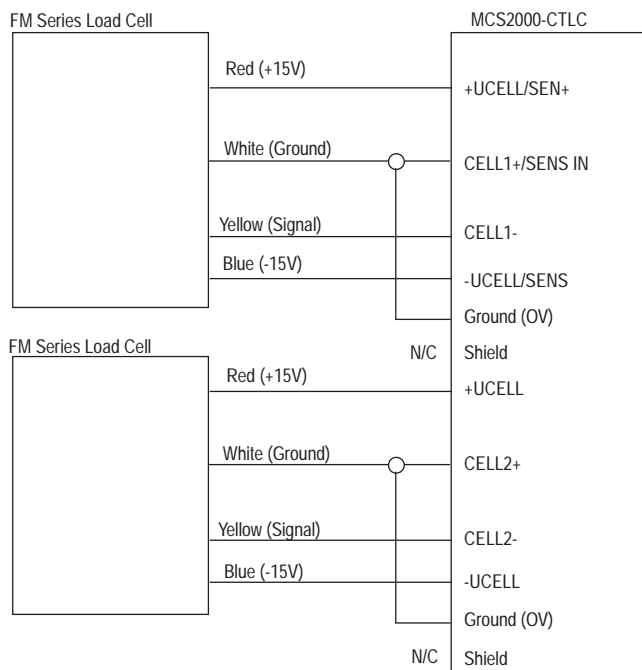

Figure 3

Notes: It is recommended to use the load cell in a compression application. It must be fitted on a flat surface in order to avoid original sensitive plate stress. Do not load the sensor before mounting it with screws on the mounting surface.

System Example:

FM Load Cell with an Electric Brake

This is a typical load cell unwind application example. The electric brake varies the tension on the web depending on the feedback from the load cell. The load cell signal is amplified and interpreted in the controller (MCS2000-CTLC). The controller then puts out a corresponding 0-10 VDC signal to the power supply and drive (MCS2000-PSDRV). The PSDRV then amplifies and interprets the signal from the controller and puts out a corresponding 0-24 VDC signal to the brake to apply either more or less braking.

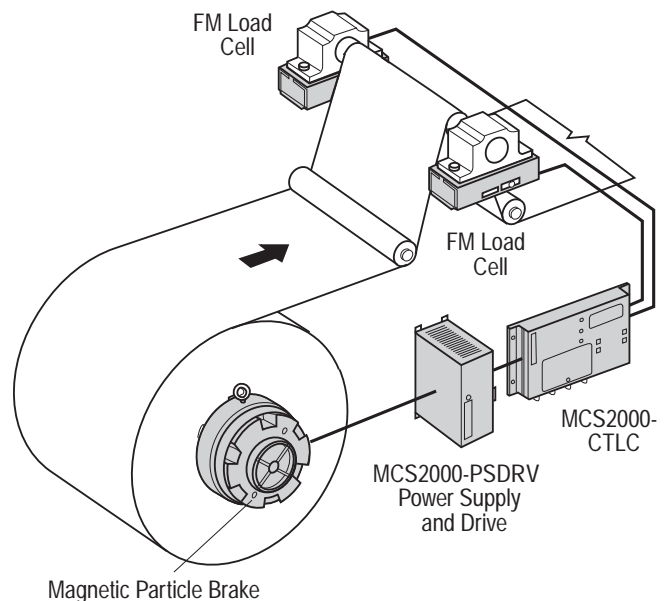
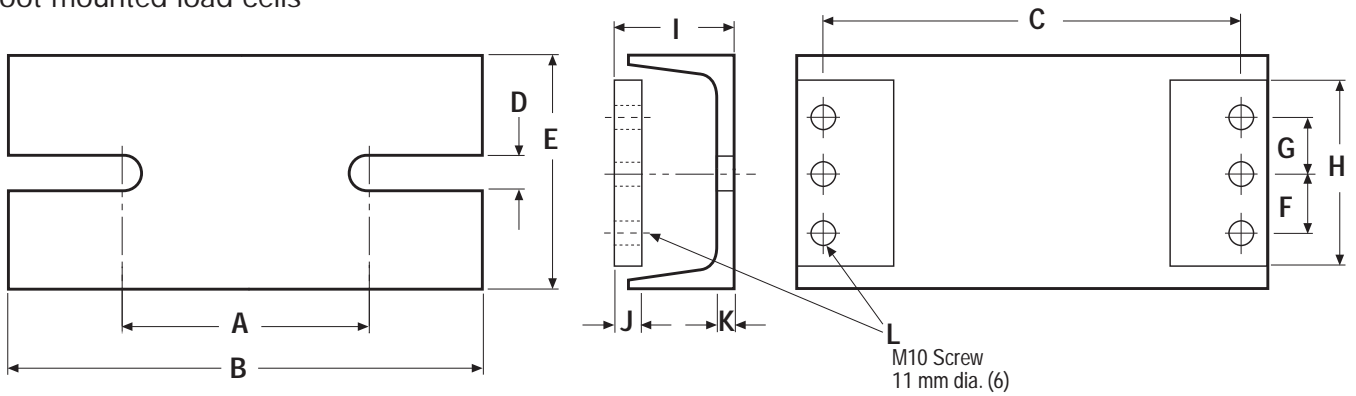

Figure 4

Dimensions

FM Series

Foot mounted load cells



(-) Denotes millimeters

Size	Load Ratings N (lbs.)	A	B	C	D	E	F	G	H	I	J	K	L
01	100 (22)												
	250 (56)												
	500 (112)	4.055	7.874	6.890	.512	4.016	.984	.984	3.150	2.047	.472	.236	.433
	1000 (225)	(103)	(200)	(175)	(13)	(102)	(25)	(25)	(80)	(52)	(12)	(6)	(11)
	2500 (562)												
	5000 (1124)												
02	10000 (2248)	5.591	8.858	7.677	.669	5.00	.984	.984	3.937	2.165	.709	.236	.433
		(142)	(225)	(195)	(17)	(127)	(25)	(25)	(100)	(55)	(18)	(6)	(11)

Figure 5

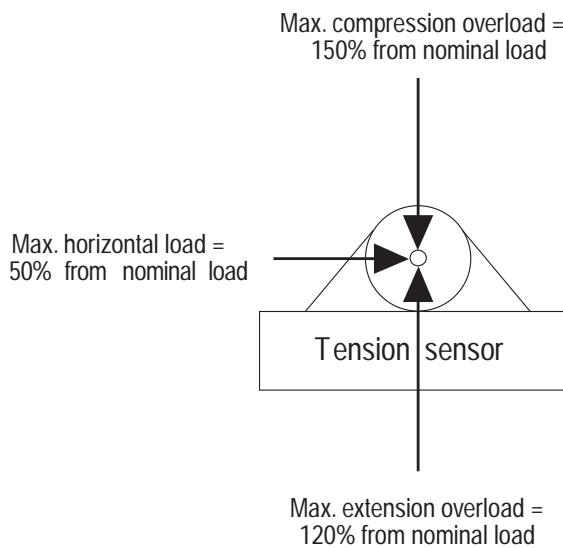

Figure 6

Warranty

Warner Electric LLC warrants that it will repair or replace (whichever it deems advisable) any product manufactured and sold by it which proves to be defective in material or workmanship within a period of one (1) year from the date of original purchase for consumer, commercial or industrial use.

This warranty extends only to the original purchaser and is not transferable or assignable without Warner Electric LLC's prior consent.

Warranty service can be obtained in the U.S.A. by returning any defective product, transportation charges prepaid, to the appropriate Warner Electric LLC factory. Additional warranty information may be obtained by writing the Customer Satisfaction Department, Warner Electric LLC, 449 Gardner Street, South Beloit, Illinois 61080, or by calling 815-389-3771.

A purchase receipt or other proof of original purchase will be required before warranty service is rendered. If found defective under the terms of this warranty, repair or replacement will be made, without charge, together with a refund for transportation costs. If found not to be defective, you will be notified and, with your consent, the item will be repaired or replaced and returned to you at your expense.

This warranty covers normal use and does not cover damage or defect which results from alteration, accident, neglect, or improper installation, operation, or maintenance.

Some states do not allow limitation on how long an implied warranty lasts, so the above limitation may not apply to you.

Warner Electric LLC's obligation under this warranty is limited to the repair or replacement of the defective product and in no event shall Warner Electric LLC be liable for consequential, indirect, or incidental damages of any kind incurred by reason of the manufacture, sale or use of any defective product. Warner Electric LLC neither assumes nor authorizes any other person to give any other warranty or to assume any other obligation or liability on its behalf.

WITH RESPECT TO CONSUMER USE OF THE PRODUCT, ANY IMPLIED WARRANTIES WHICH THE CONSUMER MAY HAVE ARE LIMITED IN DURATION TO ONE YEAR FROM THE DATE OF ORIGINAL CONSUMER PURCHASE. WITH RESPECT TO COMMERCIAL AND INDUSTRIAL USES OF THE PRODUCT, THE FOREGOING WARRANTY IS IN LIEU OF AND EXCLUDES ALL OTHER WARRANTIES, WHETHER EXPRESSED OR IMPLIED BY OPERATION OF LAW OR OTHERWISE, INCLUDING, BUT NOT LIMITED TO, ANY IMPLIED WARRANTIES OF MERCHANTABILITY OR FITNESS.

Some states do not allow the exclusion or limitation of incidental or consequential damages, so the above limitation or exclusion may not apply to you. This warranty gives you specific legal rights and you may also have other rights which vary from state to state.

Changes in Dimensions and Specifications

All dimensions and specifications shown in Warner Electric catalogs are subject to change without notice. Weights do not include weight of boxing for shipment. Certified prints will be furnished without charge on request to Warner Electric.



Warner Electric LLC
449 Gardner Street • South Beloit, IL 61080
815-389-3771 • Fax: 815-389-2582
www.warnerelectric.com